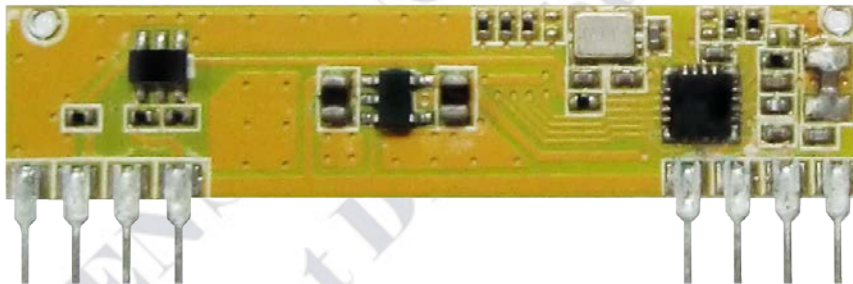

---

Wireless Narrow Band Receiver Module (RF FSK)

---

**Version History**

Version	Date	Changes
V1.01	Nov. 14, 2013	1 <sup>st</sup> . Edition

## Function Introduction

This 433.92MHZ/315MHZ RF Super-heterodyne Receiver Module RWS-433FSK is designed by WENSHING R&D team with years of solid experience to develop this high sensitivity FSK receive module. Low cost, high reliability provides the best RF solution in the market.

FSK is highly suitable for industry control or bad place for use, strong anti-jamming. Built-in automatic gain circuit (AGC), it will automatically change front-end LNA gain among received signal strength also makes signal output will not be strong or weak signals which caused by phase distortion, so that it can rise higher sensitivity. To receive the local oscillation circuit for the PLL lock loop design, no offset, and stability is high.

Working frequency is 433.92MHZ/315MHZ and receiver structure is super-heterodyne, received signal is FSK (FM). After received signal, it will output TTL signal to external decoder IC for decoding. It is convenience to employ in various products. No external component is required which makes your finished product working wirelessly at ease and to add more value into your products.

● Low-cost receiver module	● Anti-theft system
● Embedded AGC,LDO	● Wireless remote control car
● 2.8V~5.5V low working voltage	● Wireless remote control toy
● 22mA low current	● Automatic power switch control
● -106dBm high sensitivity	● Wireless security system

Model : RWS-433FSK-3

### Electrical Specification

Parameter	Specification			Unit	Condition
	Min	Type	Max		
Frequency Range		315.00		MHz	
Receiver Sensitivity	-107	-106	-108	dBm	
Data Rate	0.058		10	KBaud	
Supply Voltage, VDD	2.8		5.5	V	DC
Current		22		mA	
Operating Temperature	-20		+70	°C	

Model : RWS-433FSK-6

### Electrical Specification

Parameter	Specification			Unit	Condition
	Min	Type	Max		
Frequency Range		433.92		MHz	
Receiver Sensitivity	-107	-106	-108	dBm	
Data Rate	0.058		10	KBaud	
Supply Voltage, VDD	2.8		5.5	V	DC
Current		22		mA	
Operating Temperature	-20		+70	°C	

## Block diagram

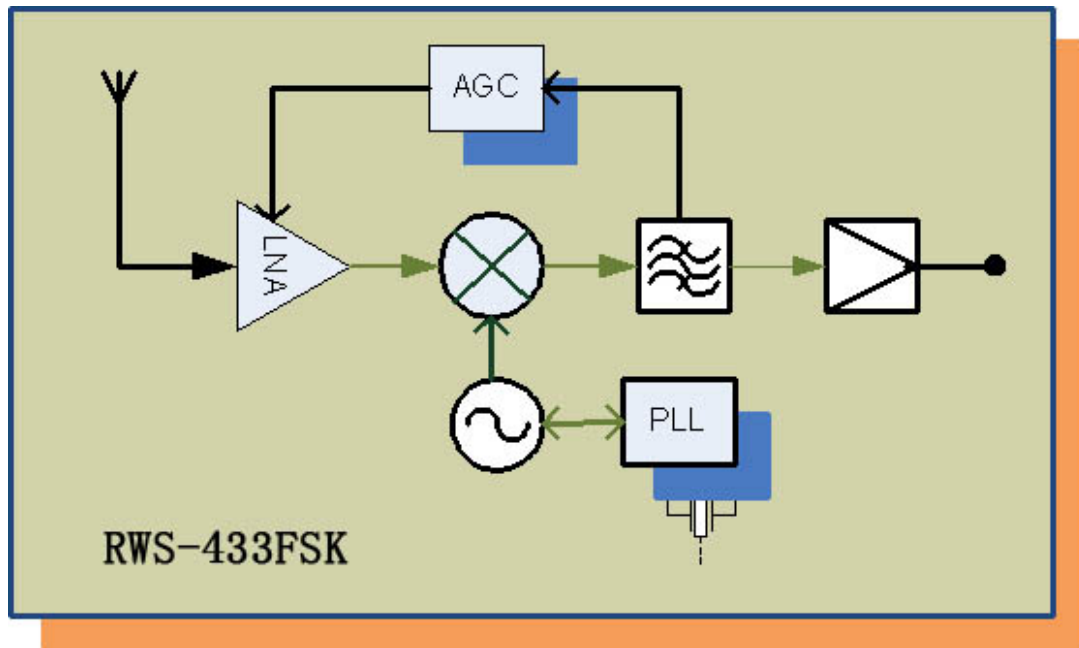

## Pin Assignment

Pin	Pin Name	Description
1	ANT	RF Input
2	GND	RF GND
3	GND	RF GND
4	Vcc	Power Supply V+
5	Vcc	Power Supply V+
6	NC	NC
7	DATA	Digital DATA Output
8	DGND	Power Supply GND

Size

(unit: mm)

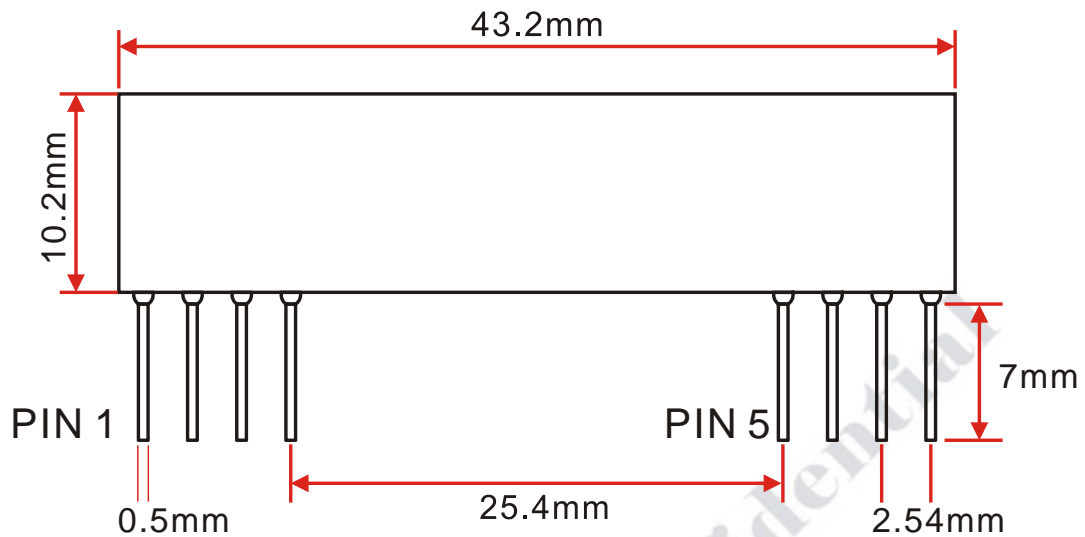

#### LAYOUT Note

Power supply should be given via 5PIN VCC and 8PIN GND. Do not connect DGND and RF GND, in order to avoid MCU EMI interfering RF signal. The design layout is shown as following.

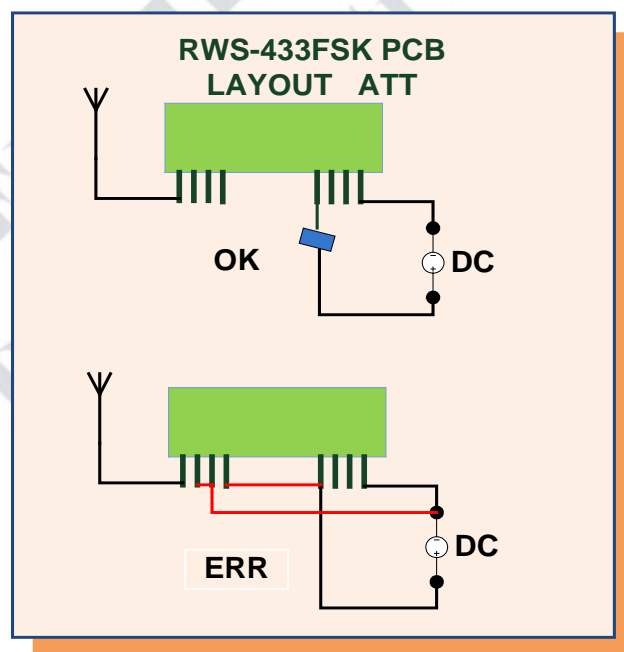

# Application Circuit

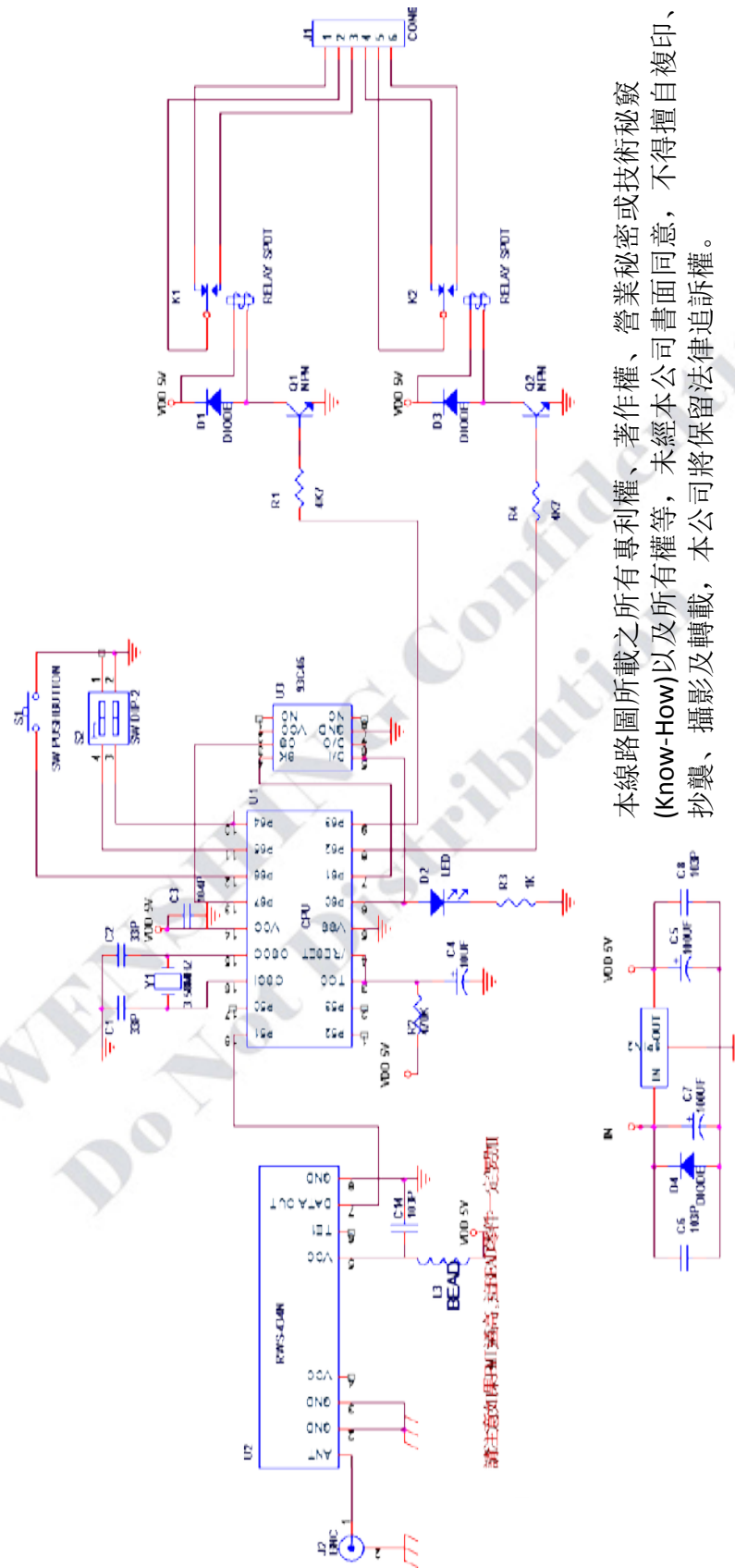

本線路圖所載之所有專利權、著作權、營業秘密或技術秘密 (Know-How) 以及所有權等，未經本公司書面同意，不得擅自複印、抄襲、攝影及轉載，本公司將保留法律追訴權。